

---

# Clarke®

## Operator's Manual

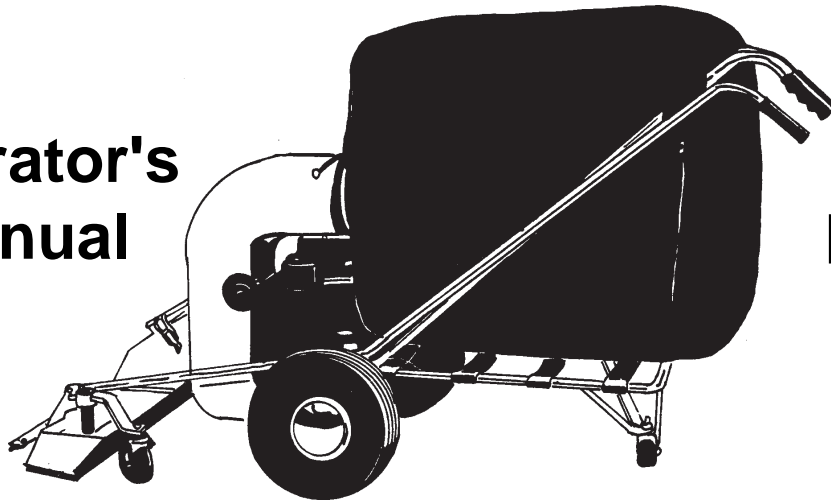

**LV-30**  
**LV-30H**

### **READ THIS BOOK**

This book has important information for the use and safe operation of this machine. Failure to read this book prior to operating or attempting any service or maintenance procedure to your Clarke machine could result in injury to you or to other personnel; damage to the machine or to other property could occur as well. You must have training in the operation of this machine before using it. If your operator(s) cannot read this manual, have it explained fully before attempting to operate this machine.

Si Ud. o sus operadores no pueden leer el Inglés, se hagan explicar este manual completamente antes de tratar el manejo o servicio de esta máquina.

All directions given in this book are as seen from the operator's position at the rear of the machine.

For new books write to: Clarke®, 2100 Highway 265, Springdale, Arkansas 72764.

# Table of Contents

<b>Operator Safety Instructions .....</b>	<b>3</b>
<b>Introduction &amp; Machine Specifications .....</b>	<b>4</b>
<b>How to Prepare the Machine for Operation .....</b>	<b>5</b>
<b>How to Check the Oil .....</b>	<b>5</b>
<b>How to Fill the Gasoline Tank .....</b>	<b>5</b>
<b>How to Start the Vacuum .....</b>	<b>6</b>
<b>How to Stop the Machine .....</b>	<b>6</b>
<b>How to Operate the Machine .....</b>	<b>7</b>
<b>Maintenance Procedures .....</b>	<b>8</b>
<b>When to Change the Oil .....</b>	<b>8</b>
<b>How to Lubricate the Litter Vac .....</b>	<b>8</b>
<b>How to check the tires .....</b>	<b>8</b>
<b>Engine Maintenance .....</b>	<b>8</b>
 <b>SECTION II Parts and Service Manual</b>	
<b>Assembly drawing .....</b>	<b>10</b>
<b>Parts List .....</b>	<b>11</b>

## OPERATOR SAFETY INSTRUCTIONS



**WARNING**



**AVERTISSEMENT**



**ADVERTENCIA**

<b>DANGER</b> means:	Severe bodily injury or death can occur to you or other personnel if the <b>DANGER</b> statements found on your machine or in your Owner's Manual are ignored or are not adhered to. Read and observe all <b>DANGER</b> statements found in your Owner's Manual and on your machine.
<b>WARNING</b> means:	Injury can occur to you and to other personnel if the <b>WARNING</b> statements found on your machine or in your Owner's Manual are ignored or are not adhered to. Read and observe all <b>WARNING</b> statements found in your Owner's Manual and on your machine.
<b>CAUTION</b> means:	Damage can occur to the machine or to other property if the <b>CAUTION</b> statements found on your machine or in your Owner's Manual are ignored or are not adhered to. Read and observe all <b>CAUTION</b> statements found in your Owner's Manual and on your machine.



**DANGER:**

Failure to read the Operator's Manual prior to using this machine could result in injury to you or to other personnel; damage to the machine or to other property could occur as well. You must have training in the operation of this machine before using it. If your operator(s) cannot read this manual, have it explained fully before attempting to operate this machine



**DANGER:**

Machines can cause an explosion when operated near flammable materials and vapors. Do not use this machine with or near fuels, grain dust, solvents, thinners, or other flammable materials.



**DANGER:**

Operating a machine that is not completely or fully assembled could result in injury or property damage. Do not operate this machine until it is completely assembled.



**DANGER:**

Filling a machine with fuel in an explosive or poorly-ventilated area can cause an explosion. Only fill the fuel tank in an open area. Do not fill the tank near open flames or while the machine is running. Do not smoke while filling the tank. Do not over-fill the tank. Wipe up any spills. Tighten the cap on the tank when finished.



**WARNING:**

Removal of the impeller cover or other materials from the machine, without disconnecting the spark plug, could result in serious injury to the operator.



**WARNING:**

Failure to read and observe all safety statements found on your machine or in this Operator's Manual can result in serious injury or damage. Read and observe all safety statements. Make sure that all labels, decals, warnings, cautions, and instructions are fastened to the machine. Get new labels from your authorized Clarke distributor.



**WARNING:**

To avoid inhaling exhaust fumes, operate machine in a well ventilated area only. Engine exhaust fumes are dangerous to your health.



**CAUTION:**

Maintenance and repairs performed by unauthorized personnel could result in damage or injury. Maintenance and repairs performed by unauthorized personnel will void your warranty. Servicing of this unit must always be referred to an authorized Clarke distributor.



**CAUTION:**

Use of this machine to move other objects or to climb on could result in injury or damage. Do not use this machine as a step or furniture. Do not ride on this machine.

## Introduction and Machine Specifications

The LV-30 Litter Vac is powered by a 6hp gasoline engine and generates 900 CFM to handle the toughest cleaning jobs. This commercial vacuum cleaner can clean debris from large indoor and outdoor areas. The LV-30 is designed for uneven terrain and with a hose and wand attachment its versatility is greatly enhanced.

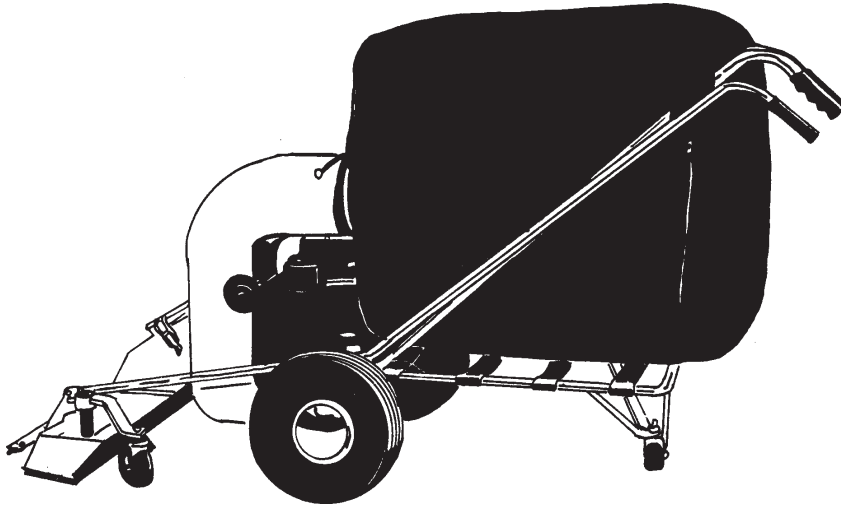

- ◆ Large 11 cu. ft. bag with side zipper disposal system.
- ◆ Non-rusting fan housing allows easy passage of debris to bag.
- ◆ Heavy duty impeller picks up bottles, cans, washers, sticks, leaves.
- ◆ Large wheels allows the LV-30 to traverse rough terrain, curbs, and gutters.
- ◆ Powered by an industrial 5.5 HP Tecumseh or Honda engine with low oil shut-off.
- ◆ Large adjustable up-down front swivel casters.
- ◆ Trap door allows large debris to pass into the vacuum chamber.

### Machine Specifications:

Power Source	5.5 HP Tecumseh or Honda recoil start
Cleaning Path Bag/ Hopper Capacity	30" path, bag holds (76.2 cm) 11 cu. ft. (.31 cu. meter)
Frame	Steel & Polydur
Dimensions	75" L x 41½" H 190.5 cm x 76.8 cm x 105.4 cm
Weight	167 lbs. (75.8k)
Shipping Weight	194 lbs. (88.0k)

## How to Prepare The Machine for Operation

1. Before assembling the Litter Vac, remove all parts of the machine from the two cartons. Fasten the handles and the filter bag to the main frame. Follow the instructions in the handle carton.

### HOW TO CHECK THE OIL

**⚠ WARNING:** Do not check the engine oil level when the engine is running. Failure to check the oil level before you use the machine can destroy the engine. Always make sure the machine has the correct amount of oil.

Follow this procedure to check the oil:

1. Make sure the machine is on level ground.
2. Turn the cap marked "Engine Oil" counterclockwise.
3. Lift the dipstick out of the tube.
4. If the mark is below "OK", add oil. See figure 1.
5. When adding oil, make sure the oil does not pass the mark "FULL" on the dipstick.

See the engine manual for the correct type of oil.

### HOW TO FILL THE GASOLINE TANK

**⚠ WARNING:** Fill the gasoline tank in an open area. Do not fill the tank near open flames. Do not fill the gasoline tank while the engine is running. Gasoline is very flammable and creates vapors. Serious injury to the operator or others could occur.

**⚠ WARNING:** Gasoline is very flammable. When filling the gasoline tank, make sure the gasoline does not enter the extension. See figure 2. Make sure you do not spill any gasoline. Use a cloth to remove spilled gas.

**⚠ WARNING:** Do not mix oil with the gasoline. Damage to the engine could occur.

Fill the gasoline tank only with regular unleaded gasoline. The tank holds four quarts. Use a clean container. Prevent dirt and debris from falling into the tank. Always tighten the cap on the tank.

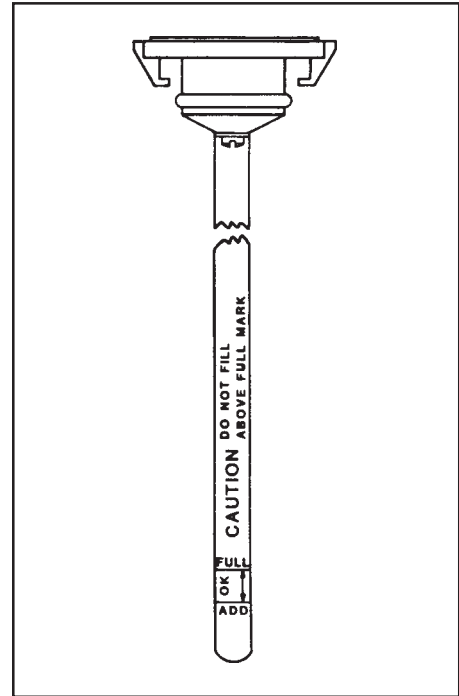

Figure 1

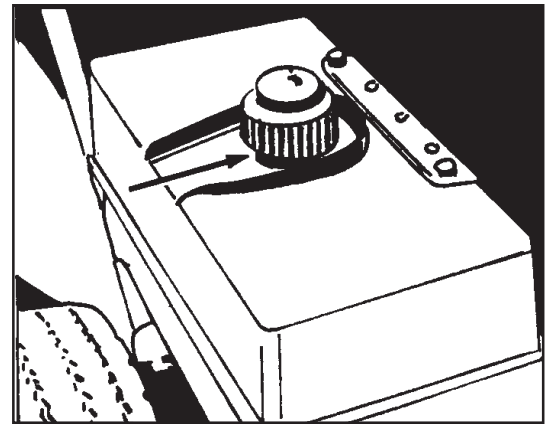

Figure 2

## How to Prepare The Machine for Operation

### How To Start Your Vacuum

To start your vacuum follow this procedure:

1. Make sure the spark plug is connected to the plug.
2. Move the throttle lever to the half throttle position. See figure 3.
3. If the engine has not run for a period of time, move the choke lever to the second detent toward the "Arrow" mark. See figure 4.
4. Pull the starting cord handle.
5. When the engine starts, move the choke lever to the "OFF" position.

NOTE: If the engine does not start, move the choke to the "OFF" position. Pull the starting cord again.

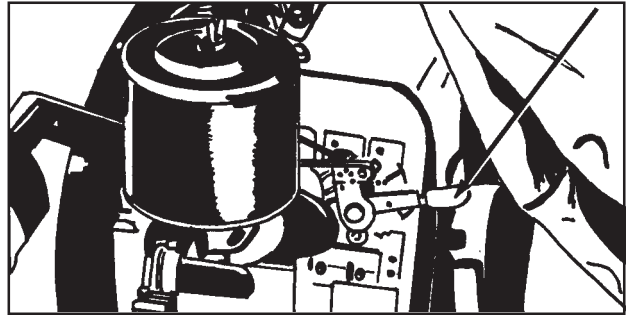

Figure 3



Figure 4

### HOW TO STOP THE MACHINE

To stop the engine, follow this procedure:

1. Move the throttle to the "idle" position.

**⚠ WARNING:** Make sure your hand does not touch the spark plug before the grounding strip touches the spark plug cap. Severe shock could occur.

2. Push the strip against the spark plug cap.
3. Hold the strip against the spark plug cap until the engine stops.

## HOW TO OPERATE THE MACHINE

Move the machine over the area to be cleaned. To lift objects too large to go under the intake housing, pull the intake door handle. See figure 5.

See figure 6. The scraper (1) and the shield (2) can be adjusted to three positions. When the vacuum is being used on an uneven outdoor surface, do the following:

1. Make sure the scraper is .06 of an inch above the surface.
2. Make sure the shield is in the lowest position above the surface.

To adjust the scraper and the shield, do the following:

1. Pull the pin (3). See figure 6.
2. Move the bracket support to the highest setting on the housing shaft (4). See figure 6.
3. Make sure the disconnect pin locks into the detent.

If the scraper is not .06 of an inch above the surface, do the following:

1. Loosen the five scraper screws.
2. If the scraper is more than .06 of an inch above the surface, pull the bottom edge of the scraper.
3. If the scraper is level with or below the surface, push the edge of the scraper.
4. Adjust the bottom edge so that it is .06 of an inch above the surface.
5. Tighten the five scraper screws.

**CAUTION:** Pieces of wire, metal, and rope can damage the vacuum. Do not try to lift or vacuum these objects.

**NOTE:** When an object is held between the impeller and the housing, do the following:

1. Stop the machine.
2. Disconnect the ignition wire from the spark plug.
3. Put the ignition wire behind the stop lever.
4. Remove the intake cap.

**WARNING:** Do not put your fingers into the housing. Severe injury to the fingers or operator could occur.

5. Use a tool to reach into the intake housing to remove the object.

When using the machine on uneven areas, set the casters to an outward position.

### Optional Equipment

To remove heavy metal clippings and sand, use a special bag support and caster assembly (part # 760641). See figure 7.

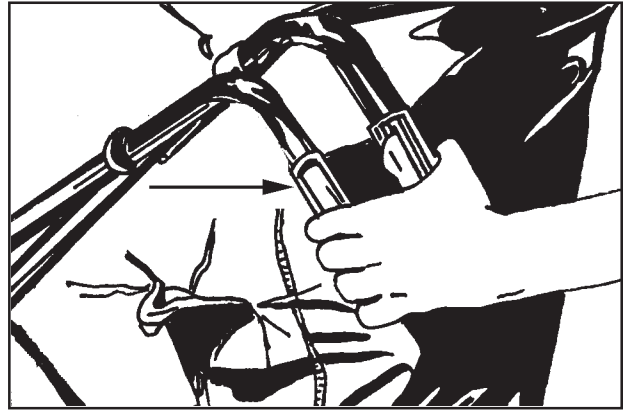

Figure 5

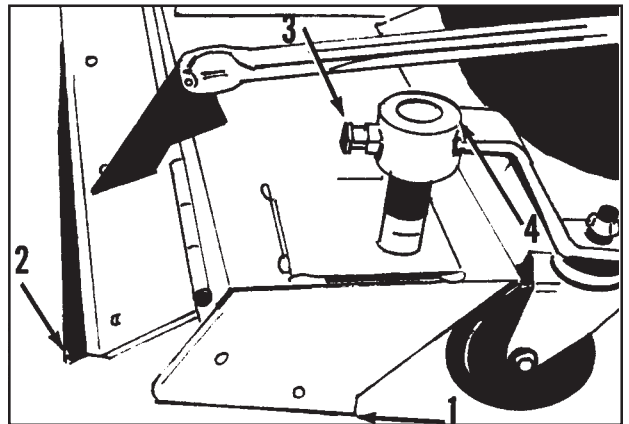

Figure 6

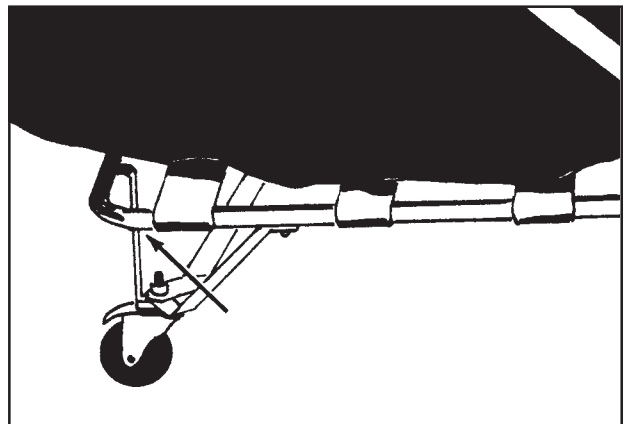

Figure 7

## MAINTENANCE PROCEDURES

Keep the vacuum clean, it will have longer life and need fewer repairs.

### When To Change The Oil

To change the oil, follow this procedure:

1. Drain the oil from the engine after the first two hours of use.
2. Fill with 19 ounces of clean oil.

NOTE: See the engine manual for the correct type of oil.

3. After the first change of oil, drain the oil after every 25 hours of use. Fill with 19 ounces of clean oil.

 **CAUTION: Never operate the engine when the level of oil is below the "ADD" mark on the dipstick. The engine could be damaged.**

4. Check the oil level every five hours of use. When the machine is used in very dirty areas, frequently check the oil level. If the level of oil is below the "ADD" mark, add oil.

### How To Lubricate The Litter Vac

Every fifteen days of use, apply lubricant to the caster wheel axle, the caster pivot, and the main bushings.

### How To Clean The Filter Bag

1. Wash the filter bag when the bag is dirty.
2. Dry the filter bag before using.

### How To Check The Tires

Each day inspect the tires on the vacuum. Use a low pressure gauge to check the air pressure. The air pressure in each tire must be 35 psi.

### Engine Maintenance

Clean the plastic filter and the cooling fins after every 25 hours of use. The engine manual tells how to clean the filter and the cooling fins.

The engine used on the Clarke® Litter Vac is a Tecumseh H-60, 5.5 HP engine or Honda GX160 engine. For service on the engine, see a Tecumseh or Honda dealer.



---

# **Clarke<sup>®</sup>**

## **LV-30**

## **LV-30H**

### **Section II**

## **Parts and Service Manual**

(70463A)

Clarke®  
**Model LV-30 & LV-30H**  
**Assembly Drawing-11/02**

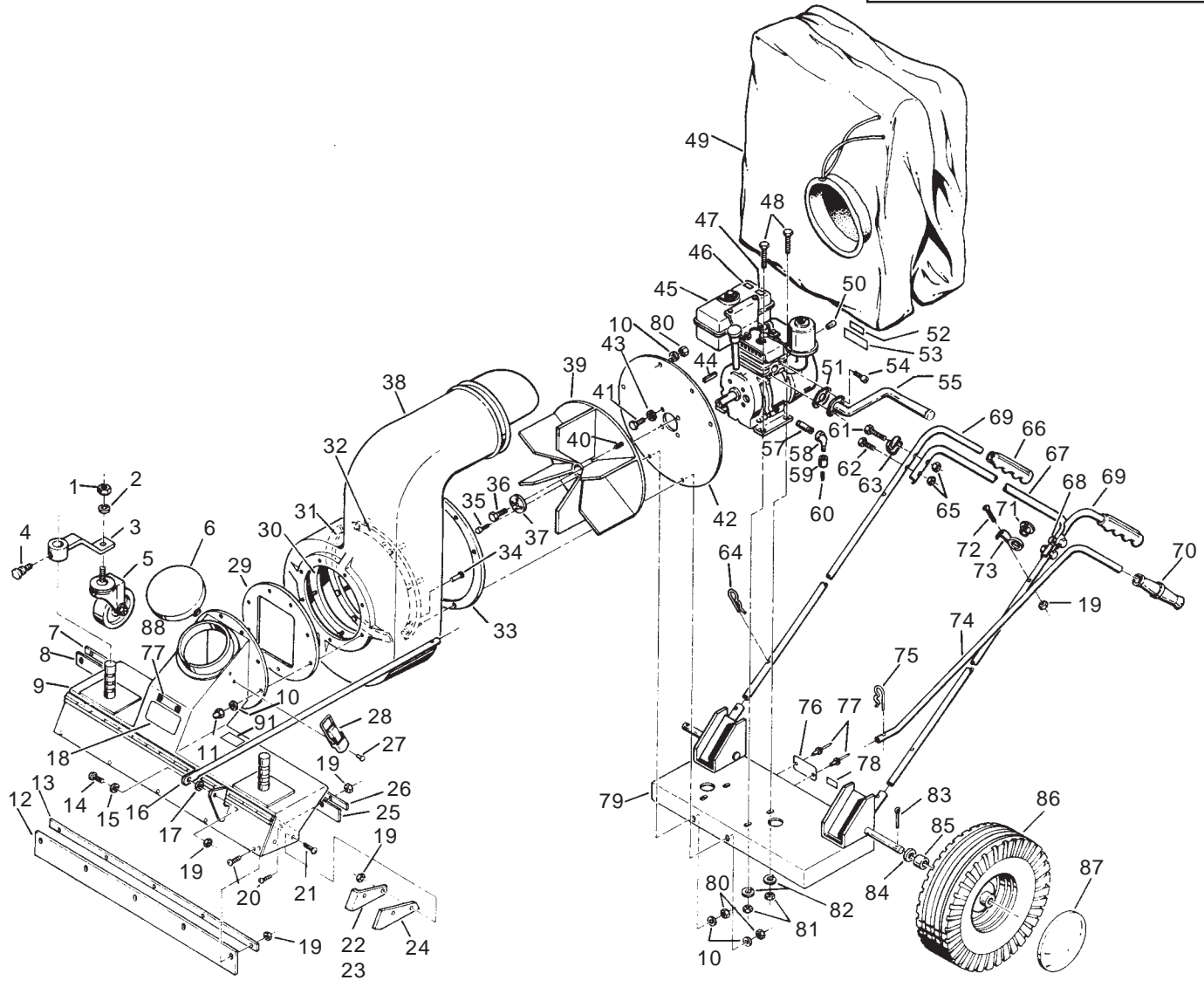
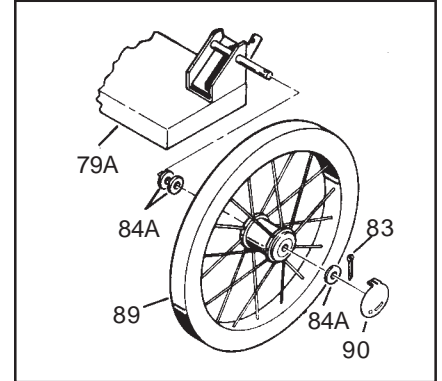

Clarke®  
**Model LV-30 & LV-30H**  
**Parts List - 9/03**

Ref.	Part No.	Description	Qty.	Ref.	Part No.	Description	Qty.
1	920196	Nut 1/2-13 Hex Jam	2	46	215110	Label-Caution, Spanish	1
2	980626	Washer-1/2 Lock	2	47	215103	Label-Caution	1
3	760842	Bracket-Caster Support Asm.	2	48	962158	Screw-5/16-18 x 7/8 Hex	4
4	766742	Pin Assembly-Disconnect	2	*	962324	Screw-5/16-18 x 1.5 Hx Hd	4
5	769744	Caster-Front Support	2	49	30521A	Bag-Filter Plain	1
6	60050A	Cover-Intake	1	50	765044	Knob-Throttle Control-Svc. Only	1
7	762043	Clamp-Rear R.H.	1	51	34267A	Gasket-Muffler Mtg. (Honda Only)	1
8	768542	Scraper-R.H.	1	52	215104	Label-Warning	1
9	15711B	Housing Assembly-Intake	1	53	215106	Label-Warning	1
10	980646	Washer-1/4"	15	55	62812A	Extension Assembly Honda	1
11	920180	Nut-Acorn 1/4-20	7	57	755721	Nipple-1/4-18 Short	1
12	760741	Blade-Door	1	58	822806	Elbow-90° Street	1
13	762047	Clamp-Door Blade	1	59	170266	Coupling-1/4 NPT	1
14	962483	Screw #10-24 x 5/8	1	60	ref.	Drain Plug (part of engine)	1
15	980982	Washer #10 x 1/2	1	61	85702A	Screw-1/4-20 x 1 5/8 Hex St. Cap	2
16	763945	Handle-Lower	1	62	85701A	Screw-1/4-20 x 1 1/2 Hex St. Mach	2
17	768242	Spacer-Handle	1	63	764541	Hook-Bag Right	1
18	70462A	Label	1	64	766740	Pin-Locking	2
19	920296	Nut-#10-24 Elastic Stop	16	65	920284	Nut-1/4-20 Stop	4
20	84808A	Screw #10-24 x 3/4 Rd. Hd.	10	66	763740	Grip-Handle	2
21	962109	Screw #10-24 x 5/8	4	67	761340	Brace-Handle	1
22	762045	Clamp-R.H. Shield	1	68	764540	Hook-Bag Left	1
23	762046	Clamp-L.H. Shield	1	69	763940	Handle	2
24	767841	Shield	2	70	763701	Grip-Handle	1
25	768543	Scraper-L.H.	1	71	761140	Bushing-Handle	1
26	762044	Clamp-Rear L.H.	1	72	962009	Screw #10-24 x 1 1/4 Rd St. Mach	1
27	930086	Rivet-3/16 x .450	4	73	763840	Guide-Handle	1
28	682006	Lid Clamp Assembly	2	74	763946	Handle-Upper	1
29	763444	Gasket-Intake Hsg. Flange	1	75	766744	Pin-Locking	1
30	66909A	Retainer Assembly	1	76		Plate-Serial	1
31	66908A	Retainer Assembly	1	77	930112	Rivet-1/8 Pop	4
32	66907A	Retainer Assembly	1	78	805160	Label-Inspection	1
33	763443	Gasket-Impeller Housing	1	79	763264	Frame Assembly-Small Wheel	1
34	930113	Rivet-Pop 1/8	5	79a	763263	Frame Assembly-Large Wheel	1
35	962241	Screw-#10-24 x 1/2	4	80	920208	Nut-1/4-20	8
36	962747	Screw-3/8-24 x 3/4 Nylok Hex Hd	1	81	920110	Nut-5/16-18 Elastic Stop	4
*	962867	Screw 7/16-20 x 1 Hex Head	1	82	980651	Washer-5/16 Plain	4
37	980013	Washer-Clamp Honda & Tecumseh	1	83	925006	Pin-1/8 x 1 1/4 Lg. Cotter	2
38	35210B	Housing-Impeller	1	84	980679	Washer-13/16 x 1 1/4 x 1/8 Flat	2
39	764841	Impeller Honda & Tecumseh	1	85	768244	Spacer-Wheel	2
40	962593	Screw-1/4-20 x 3/8 Nylok	1	86	769701	Wheel-Assembly	2
41	962603	Screw-5/16-24 x 1 1/4 Hex.	4	87	194446	Cap Hub w/Retainer	2
42	766664	Plate Assembly-Flange	1	88	765141	Label-Caution	1
43	980652	Washer-5/16 Standard Lock	4	89	769740	Wheel-Large	2
44	915570	Key-1/4 x 1/4 x 2 1/4 Square	1	90	761541	Hub-Cap	2
45	50035B	Engine-Gas 5.5 hp Tecumseh	1	91	70651A	Label, Div. of ALTO	1
*	53808A	Engine-Gas 5.5 hp Honda	1				

\* Indicates parts that are for the LV 30H (Honda engine) only.

NOTE: ♦ indicates a change has been made since the last publication of this manual.

♦ Optional Accessories:
760641 Bag Support Assembly
764140 Kit, Intake 6" x 10' Hose
764141 Kit, Intake 4" x 10' Hose



# CLARKE PRODUCT SUPPORT BRANCHES

## U. S. A. Locations

### PRODUCTION FACILITIES

**Clarke®**, Springdale, Arkansas  
2100 Highway 265  
Springdale, Arkansas 72764  
(479) 750-1000  
**Customer Service - 1-800-253-0367**  
**Technical Service - 1-800-356-7274**

**American Lincoln®**, Bowling Green, Ohio 43402  
1100 Haskins Road

### SERVICE FACILITIES

**Clarke®**, Elk Grove, Illinois 60007  
2280 Elmhurst Road  
(847) 956-7900

**Clarke®**, Denver, Colorado 80204  
1955 West 13th Ave.  
(303) 623-4367

**Clarke®**, Houston, Texas 77040  
7215 North Gessner Road  
713-937-7717

### SERVICE AND SALES FACILITY

**American Lincoln® / Clarke**, Madison Heights,  
Michigan 48071-0158  
29815 John R.  
(810) 544-6300

**American Lincoln® / Clarke**, Marietta, Georgia 30066  
1455 Canton Road  
(770) 973-5225

**Clarke®**

**Clarke American Sanders**

**A.L. Cook**

**Customer Service Headquarters and Factory**  
2100 Highway 265  
Springdale, Arkansas 72764  
(479) 750-1000

**Technical Service**  
1-800-356-7274

## European Locations

### PRODUCTION FACILITIES

ALTO Danmark A/S, Aalborg  
Blytaekervej 2  
DK-9000 Aalborg  
+45 72 18 21 00

ALTO Danmark A/S, Hadsund  
Industrikvarteret  
DK-9560 Hadsund  
+45 72 18 21 00

### SALES SUBSIDIARIES

ALTO US - Canada, Ontario (Canada)  
4080 B Sladeview Crescent Unit 1  
Mississauga, Ontario L5L 5Y5  
(905) 569 0266

ALTO Overseas Inc., Sydney (Australia)  
1B/8 Resolution Drive  
Caringbah NSW 2229  
+61 2 9524 6122

ALTO Cleaning Systems Asia Pte Ltd., Singapore  
No. 17 Link Road  
Singapore 619034  
+65 268 1006

ALTO Deutschland GmbH, Bellenberg (Germany)  
Guido-Oberdorfer-Straße 2-8  
89287 Bellenberg  
+49 0180 5 37 37 37

ALTO Cleaning Systems (UK) Ltd., Penrith  
Gilwilly Industrial Estate  
Penrith  
Cumbria CA11 9BN  
+44 1768 868 995

ALTO France S.A. Strasbourg  
B.P. 44, 4 Place d'Ostwald  
F-67036 Strasbourg  
Cedex 2  
+33 3 8828 8400

ALTO Nederland B.V.  
Postbus 65  
3370 AB Hardinxveld-Giessendam  
The Netherlands  
+31 184 677 200

ALTO Sverige AB, Molndal (Sweden)  
Aminogatan 18  
Box 4029  
S-431 04 Molndal  
+46 31 706 73 00

ALTO Norge A/S, Oslo (Norway)  
Bjornerudveien 24  
N-1266  
+47 2275 1770

## **Clarke® LIMITED U.S. WARRANTY**

This Clarke Industrial/Commercial Product is warranted to be free from defects in materials and workmanship under normal use and service for a period of one year from the date of purchase, when operated and maintained in accordance with Clarke's Maintenance and Operations instructions.

This warranty is extended only to the original purchaser for use of the product. It does not cover normal wear parts such as electrical cable, rubber parts, hoses and motor brushes.

If a difficulty develops with the product, you should:

- a) Contact the nearest authorized Clarke repair location or contact the Clarke U.S. Service Operations Department, 2100 Highway 265, Springdale Arkansas 72764, for the nearest authorized Clarke repair location. Only these locations are authorized to make repairs to the product under this warranty.
- b) Return the product to the nearest Clarke repair location. Transportation charges to and from the repair location must be prepaid by the purchaser.
- c) Clarke will repair the product and/or replace any defective parts without charge within a reasonable time after receipt of the product.

Clarke's liability under this warranty is limited to repair of the product and/or replacement of parts and is given to purchaser in lieu of all other remedies, including INCIDENTAL AND CONSEQUENTIAL DAMAGES.

THERE ARE NO EXPRESS WARRANTIES OTHER THAN THOSE SPECIFIED HEREIN. THERE ARE NO WARRANTIES WHICH EXTEND BEYOND THE DESCRIPTION OF THE FACE HEREOF. NO WARRANTIES, INCLUDING BUT NOT LIMITED TO WARRANTY OF MERCHANTABILITY, SHALL BE IMPLIED. A warranty registration card is provided with your Clarke product. Return the card to assist Clarke in providing the performance you expect from your new floor machine.

**Clarke®**, 2100 Highway 265, Springdale, Arkansas 72764.

**Clarke reserves the right to make changes or improvements to its machine without notice.**

**Always use genuine Clarke Parts for repair.**

# **Clarke®**

**2100 Highway 265  
Springdale, Arkansas, 72764**